

RÜCKSEITENWERKZEUGE FÜR CITIZEN LANGDREHAUTOMATEN

BACKWORKING TOOLS FOR
CITIZEN AUTOMATIC LATHE

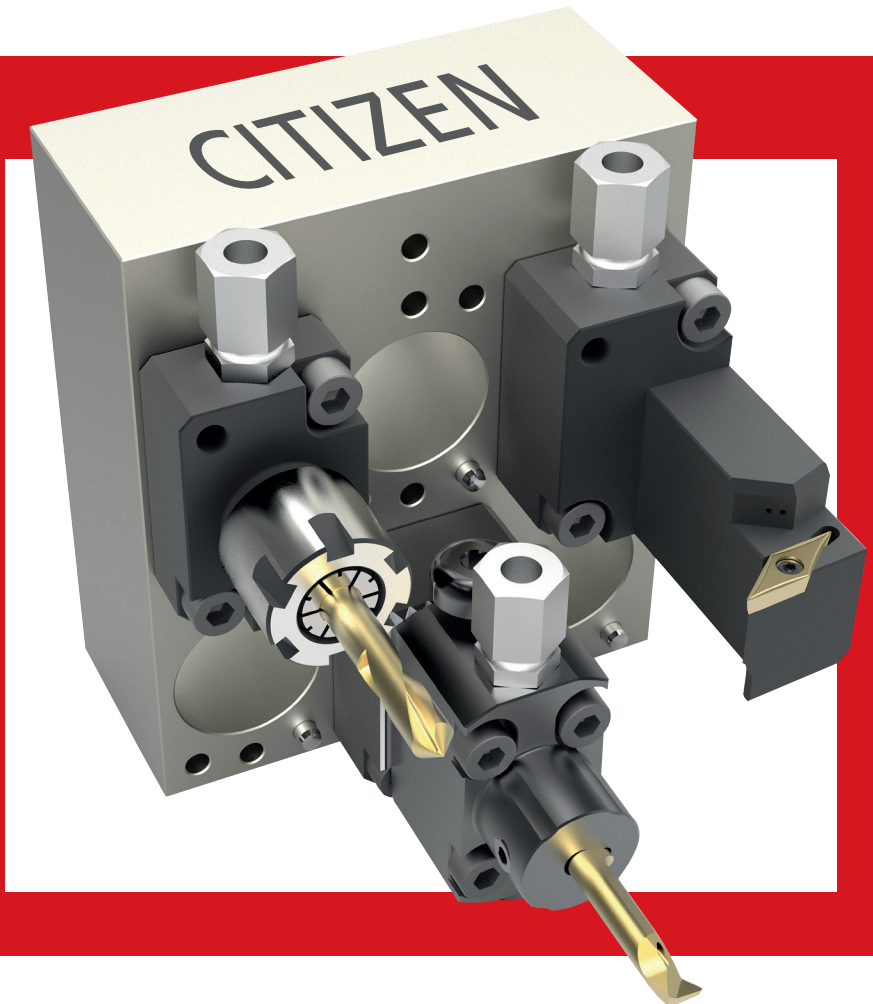

Das gesamte Werkzeugprogramm finden Sie in den folgenden Katalogen:

**Hochleistungs-Werkzeuge für Drehautomaten
Rundschaft-Werkzeuge
Höhenverstellbare Rückseitenbearbeitungs-Werkzeuge**

Bitte besuchen Sie unsere Homepage

www.Graf-Werkzeugsysteme.de

You can find the entire tool program in the following catalogs:

**High performance tooling
Round shank tools
High adjustable back working tools**

Please visit our homepage

www.Graf-Werkzeugsysteme.de

Werkzeugschlüssel/tool key

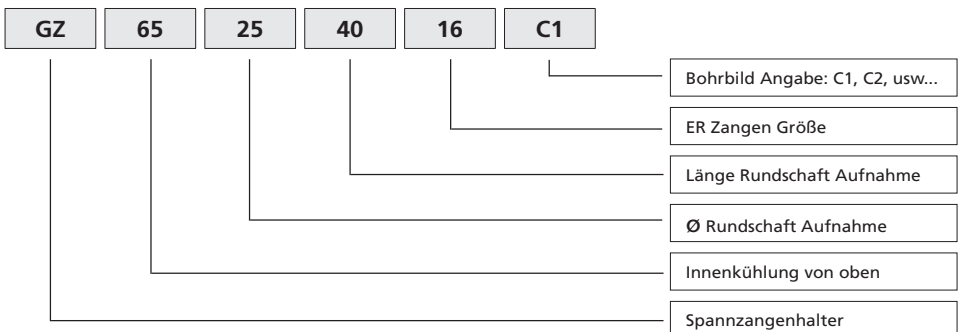
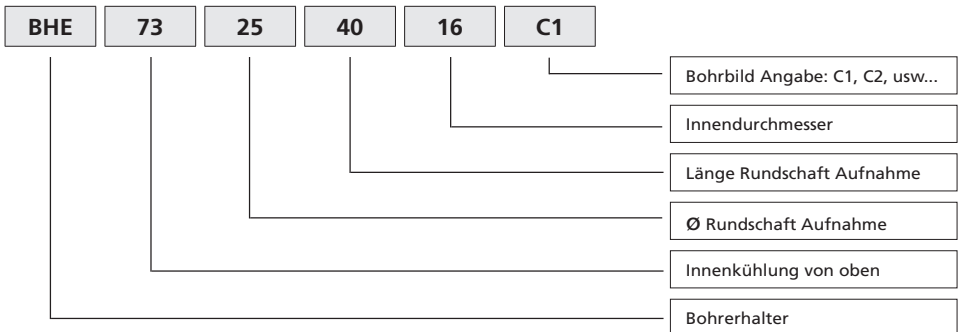
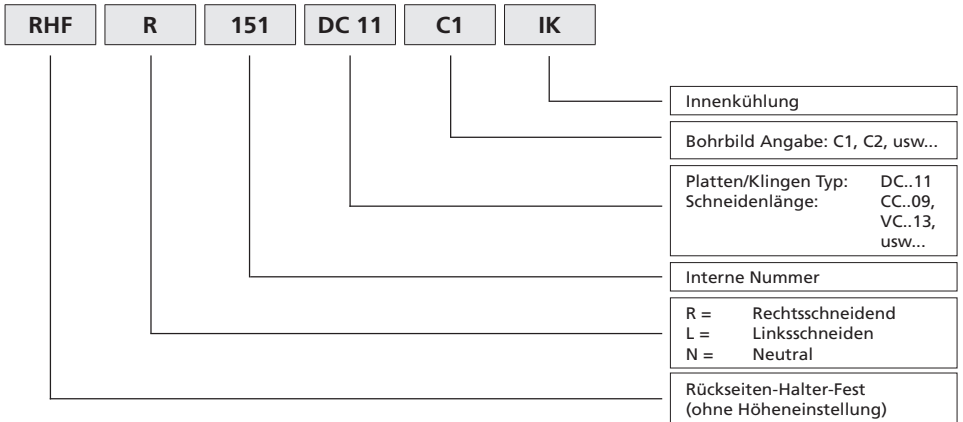

Tool key/Werkzeugschlüssel

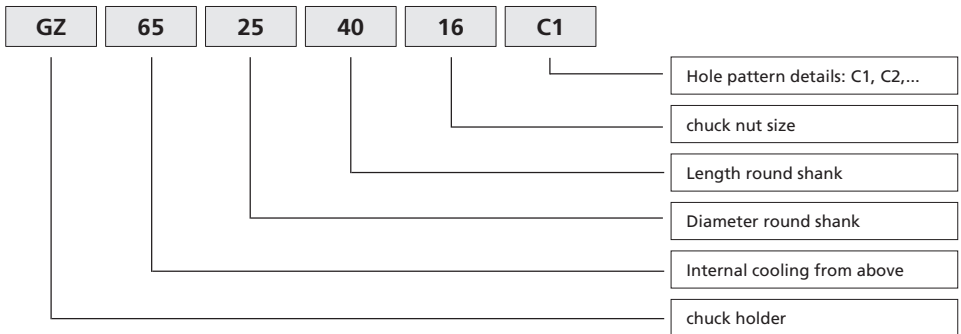
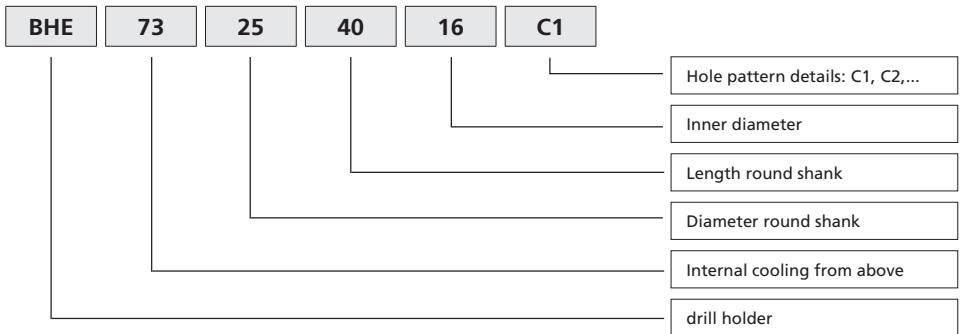
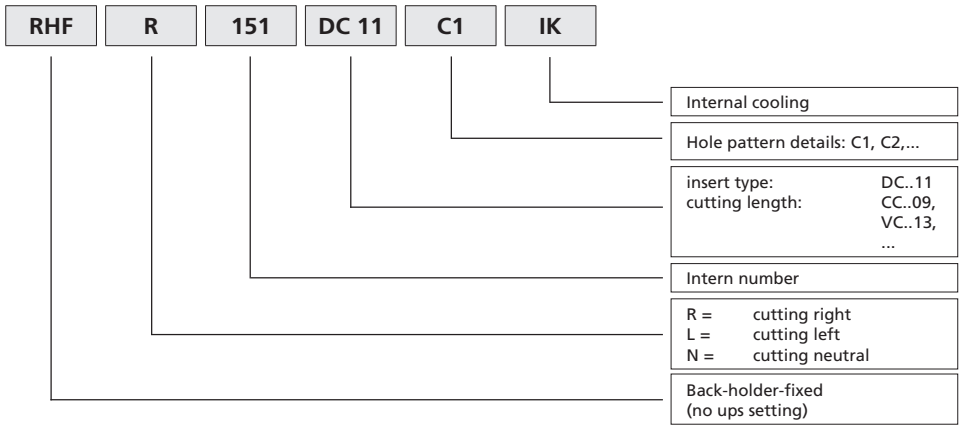

Befestigungsbeispiel Lochbild C1 - C4

Mounting example hole pattern C1 - C4

C1

- L12
- L20 Typ 8

C2

- L20 Typ 10
- L20 Typ 12
- L12

C3

- L20 Typ 8

C4

- L32 Typ 8
- L32 Typ 10
- L32 Typ 12

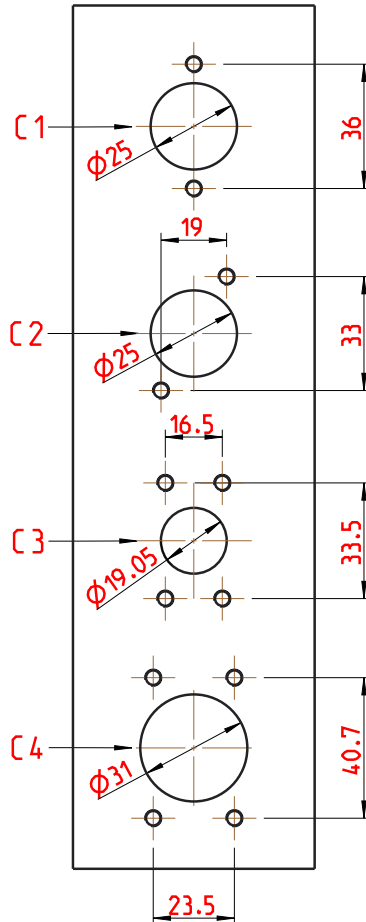

INHALTSVERZEICHNIS

SUMMARY

Anwendungen / Application:

C1 Werkzeuge / C1 Tools

Innenbearbeitung / Internal Processing

Spannzangen Halter Chuck holder	1-3
Bohrerhalter Innengekühlt Drill holder with coolant supply	4

C2 Werkzeuge / C2 Tools

Innenbearbeitung / Internal Processing

Halter für HORN-Schneidplatte Typ 105 Holder for HORN insert Typ 105	5
Spannzangen Halter Chuck holder	6-7
Bohrerhalter Innengekühlt Drill holder with coolant supply	8

Aussenbearbeitung / Outward Processing

Platte / Insert DC.. 11 T3	9-10
Platte / Insert VC.. 11 03	11
Platte / Insert 16 ER	12-13
Platte / Insert CC..09 T3	14
Platte / Insert G0004	15
Platte / Insert HORN S274	16

INHALTSVERZEICHNIS
SUMMARY

C3 Werkzeuge / C3 Tools

Innenbearbeitung / Internal Processing

Bohrerhalter Innengekühlt Drill holder with coolant supply	17
---	----

C4 Werkzeuge / C4 Tools

Innenbearbeitung / Internal Processing

Halter für HORN-Schneidplatte Typ 105 Holder for HORN insert Typ 105	18
Spannzangen Halter Chuck holder	19
Bohrerhalter Innengekühlt Drill holder with coolant supply	20

Aussenbearbeitung / Outward Processing

Platte / Insert DC.. 11 T3	21
Platte / Insert VC.. 11 03	22-23
Platte / Insert 16 ER	24
Platte / Insert CC..09 T3	25
Platte / Insert GRAF G0004	26
Platte / Insert GRAF CS08	27
Platte / Insert HORN S274	28
Berechnung des Steigungswinkel Calculating the Helix Angle.....	29-30

Rückseitenhalter, fest
Back holder, fixed

Lochbild C1
 hole pattern C1

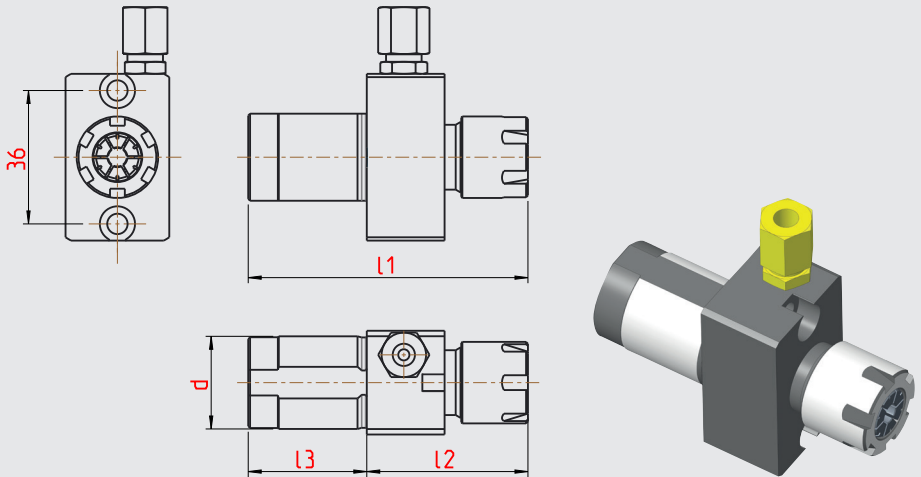

Bestellnummer Part number	Rückseitenhalter Back holder	d	l1	l2	l3	für Spannzeuge for collet
11-1182	GZ65.2532.16.C1	25	75	43	32	ER16

Abmessungen in mm
 Dimensions in mm

Hinweis/Note:

IK Anschluss oben und unten
 coolant connection at the top and bottom

Ersatzteile / Spare parts

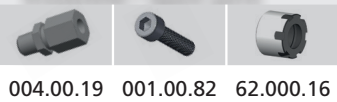

004.00.19 001.00.82 62.000.16

Abdichtbare Spannmutter muß separat bestellt werden.
 Sealed chucking nut must be orderd separately.

Rückseitenhalter, fest
Back holder, fixed

Lochbild C1
hole pattern C1

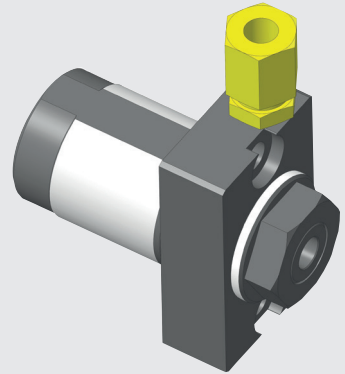
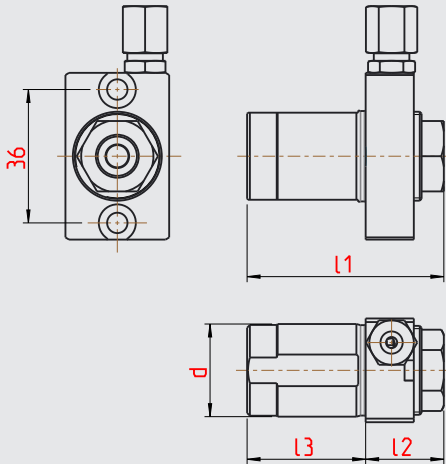

Bestellnummer Part number	Rückseitenhalter Back holder	d	l1	l2	l3	für Spannzeuge for collet
11-1181	GZ65.2532.16.C1.IM	25	53	21	32	ER16

Abmessungen in mm
Dimensions in mm

Hinweis/Note:

IK Anschluss oben
coolant connection at the top

Ersatzteile / Spare parts

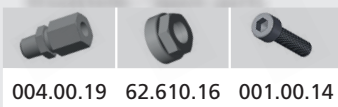

Rückseitenhalter, fest
Back holder, fixed

Lochbild C1
 hole pattern C1

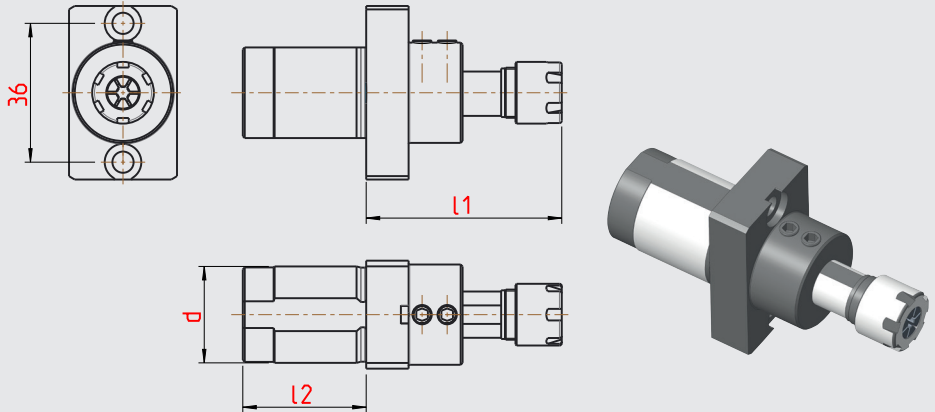

Bestellnummer Part number	Rückseitenhalter Back holder	d	l1 _{min}	l1 _{max}	l2	für Spannzeuge for collet
11-3207	GZ51.2532.11.C1	25	40	60	32	ER11

Abmessungen in mm
 Dimensions in mm

Hinweis/Note:

Spannzangenhalter mit Längenverstellung
 chuck holder with length adjustment

Ersatzteile / Spare parts



001.00.121 62.000.11

Rückseitenhalter, fest
Back holder, fixed

Lochbild C1
hole pattern C1

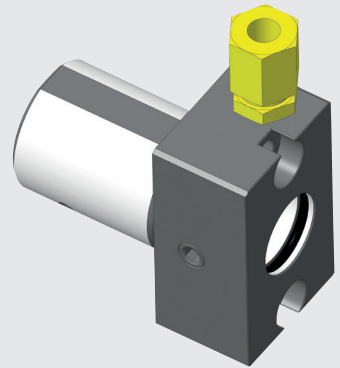
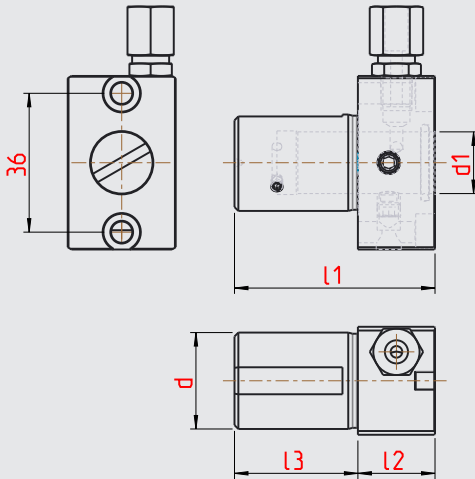

Bestellnummer Part number	Rückseitenhalter Back holder	d	d1	l1	l2	l3	für Reduzierhülsen for reduction sleeves
11-1183	BHE73.2532.16.C1	25	16	52	20	32	RH16

Abmessungen in mm
Dimensions in mm

Hinweis/Note:

IK Anschluss oben
coolant connection at the top

Ersatzteile / Spare parts



002.00.152 004.00.19 001.00.82 002.00.103

Rückseitenhalter, fest
Back holder, fixed

Lochbild C2
 hole pattern C2

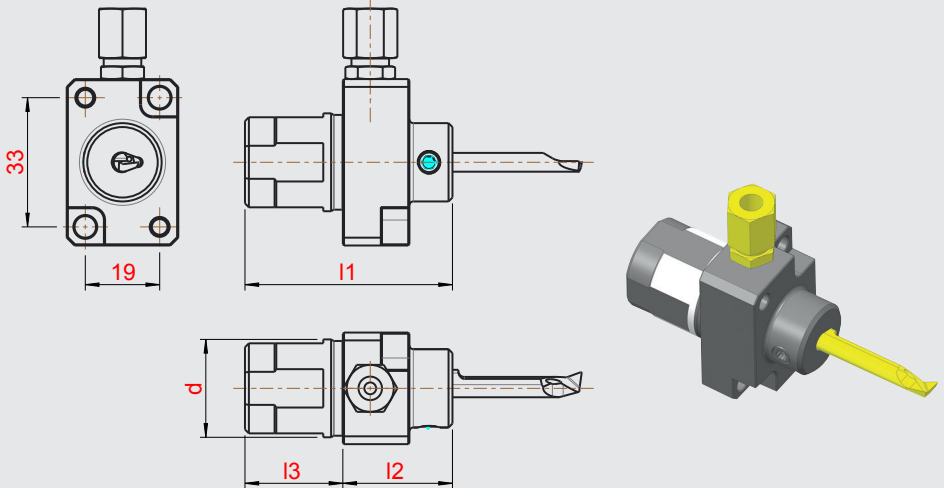

Bestellnummer Part number	Rückseitenhalter Back holder	d	I1	I2	I3	für Schneideinsatz for insert
12-1041	RHF.N.104.H105.C2.IK	25	53	28	25	Horn Typ 105

Abmessungen in mm
 Dimensions in mm

Hinweis/Note:

IK Anschluss oben und unten
 coolant connection at the top and bottom

Ersatzteile / Spare parts

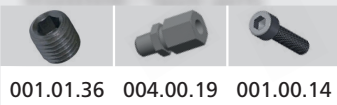

001.01.36 004.00.19 001.00.14

Rückseitenhalter, fest
Back holder, fixed

Lochbild C2
hole pattern C2

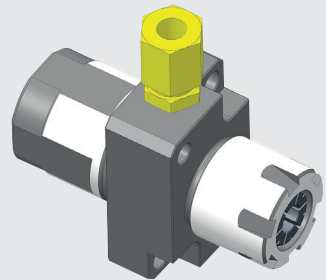
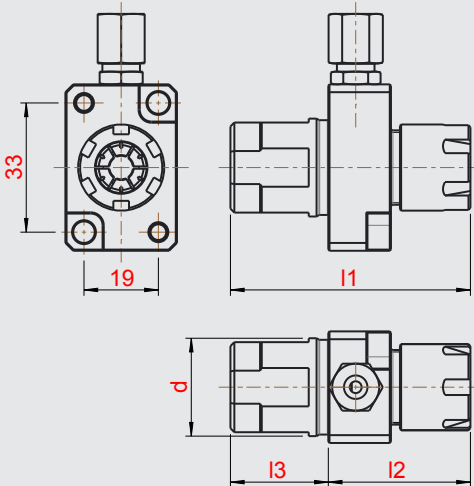

Bestellnummer Part number	Rückseitenhalter Back holder	d	l1	l2	l3	für Spannzange for collet
11-0990	GZ65.2525.16.C2	25	63	38	25	ER16

Abmessungen in mm
Dimensions in mm

Hinweis/Note:

IK Anschluss oben und unten
coolant connection at the top and bottom

Ersatzteile / Spare parts



004.00.19 62.000.16 001.00.14

Abdichtbare Spannmutter muß separat bestellt werden.
Sealed chucking nut must be ordered separately.

Rückseitenhalter, fest
Back holder, fixed

Lochbild C2
 hole pattern C2

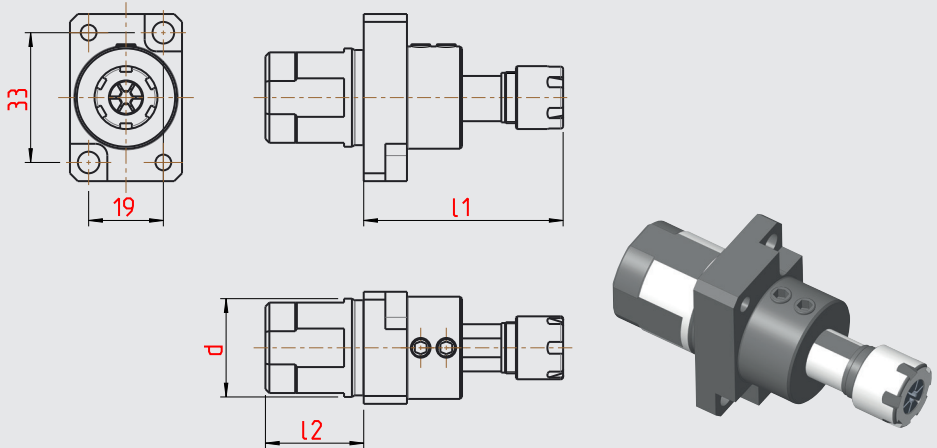



Bestellnummer Part number	Rückseitenhalter Back holder	d	l _{min}	l _{max}	l ₂	für Spannzange for collet
11-3205	GZ51.2525.11.C2	25	40	60	25	ER11
11-3206	GZ51.2525.16.C2	25	48	68	25	ER16

Abmessungen in mm
 Dimensions in mm

Hinweis/Note:

Spannzangenhalter mit Längenverstellung
 chuck holder with length adjustment

Ersatzteile / Spare parts

		
001.00.18	62.000.11	62.000.16

Rückseitenhalter, fest
Back holder, fixed



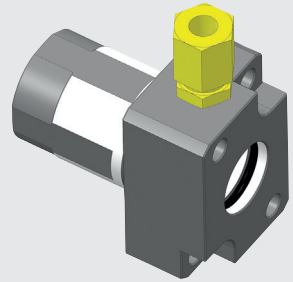
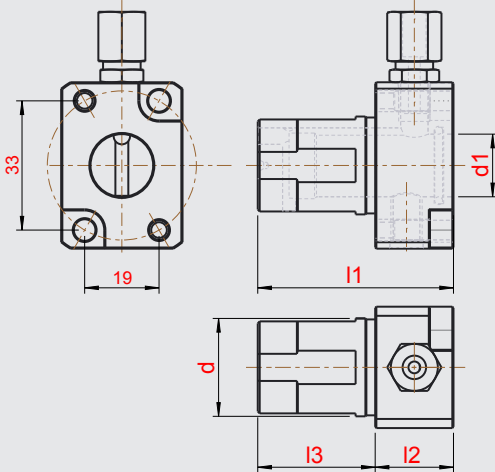

Lochbild C2
hole pattern C2



Bestellnummer Part number	Rückseitenhalter Back holder	d	d1	l1	l2	l3	für Reduzierhülsen for reduction sleeves
11-1130	BHE73.2530.16.C2	25	16	50	20	30	RH16
11-1191	BHE73.2530.12.C2	25	12	65	35	30	RH12
11-1192	BHE73.2530.10.C2	25	10	65	35	30	RH10

Abmessungen in mm
Dimensions in mm

Ersatzteile / Spare parts

				Für for
002.00.33	004.00.19	002.00.103	001.00.82	11-1130
002.00.34	004.00.19	002.00.109	001.00.80	11-1191
002.00.07	004.00.19	002.00.101	001.00.80	11-1192

Rückseitenhalter, fest
Back holder, fixed

Lochbild C2
 hole pattern C2

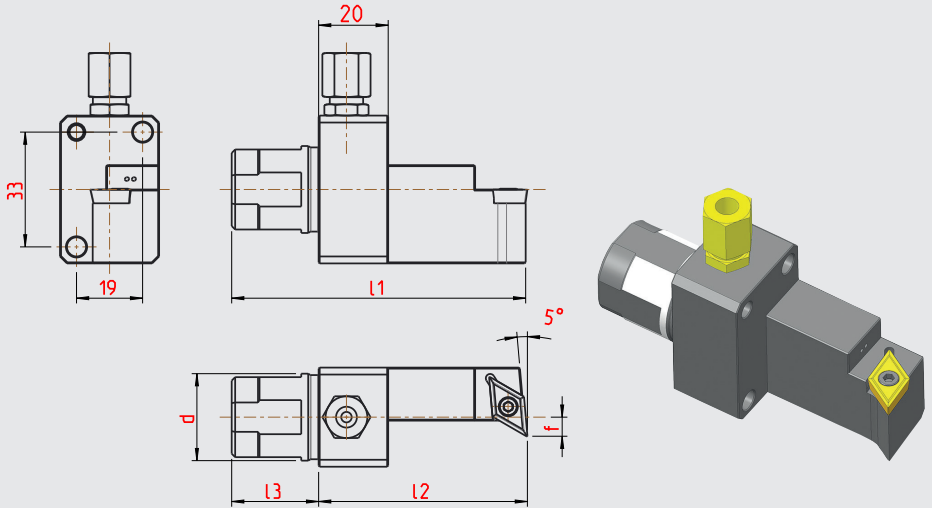

Ausführung rechtsschneidend, wie dargestellt · right cutting version shown

Bestellnummer Part number	Rückseitenhalter Back holder	d	l1	l2	l3	f	für Wendeschneidplatte for cutting insert
12-1045	RHF.R.101.DC11.C2.IK	25	85	60	25	5,5	DC... 11...
12-1172	RHF.L.101.DC11.C2.IK	25	85	60	25	5,5	DC... 11...

Abmessungen in mm
 Dimensions in mm

Hinweis/Note:

IK Anschluss oben und unten
 coolant connection at the top and bottom

Ersatzteile / Spare parts

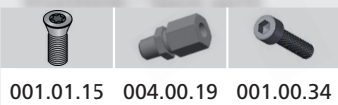

001.01.15 004.00.19 001.00.34

Rückseitenhalter, fest
Back holder, fixed

Lochbild C2
hole pattern C2

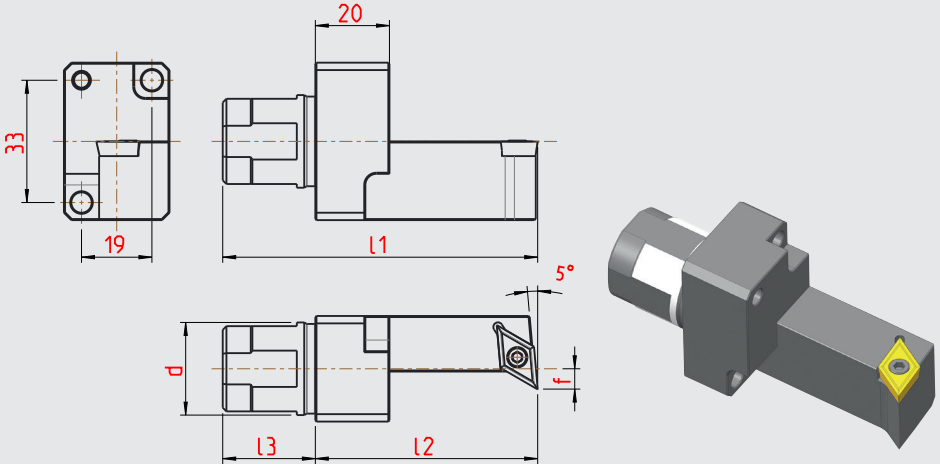

Ausführung rechtsschneidend, wie dargestellt · right cutting version shown

Bestellnummer Part number	Rückseitenhalter Back holder	d	l1	l2	l3	f	für Wendschneidplatte for cutting insert
12-1038	RHFR.101.DC11.C2	25	85	60	25	5,5	DC... 11...

Abmessungen in mm
Dimensions in mm

Ersatzteile / Spare parts



Rückseitenhalter, fest
Back holder, fixed

Lochbild C2
 hole pattern C2

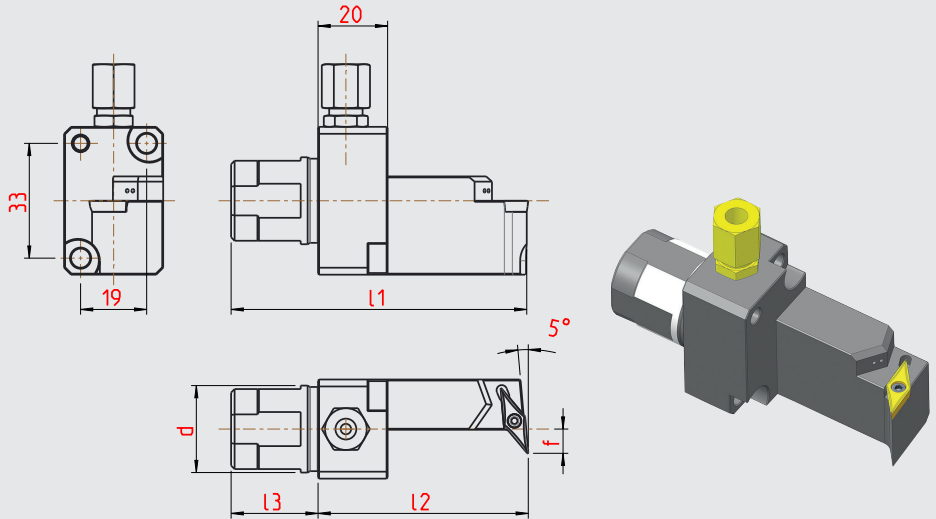

Ausführung rechtsschneidend, wie dargestellt · right cutting version shown

Bestellnummer Part number	Rückseitenhalter Back holder	d	l1	l2	l3	f	für Wendeschneidplatte for cutting insert
12-1173	RHF.R.126.VC11.C2.IK	25	85	60	25	7	VC... 11...
12-1174	RHF.L.126.VC11.C2.IK	25	85	60	25	7	VC... 11...

Abmessungen in mm
 Dimensions in mm

Hinweis/Note:

IK Anschluss oben und unten
 coolant connection at the top and bottom

Ersatzteile / Spare parts

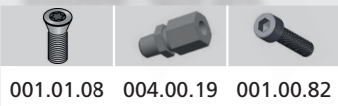

Rückseitenhalter, fest
Back holder, fixed

Lochbild C2
hole pattern C2

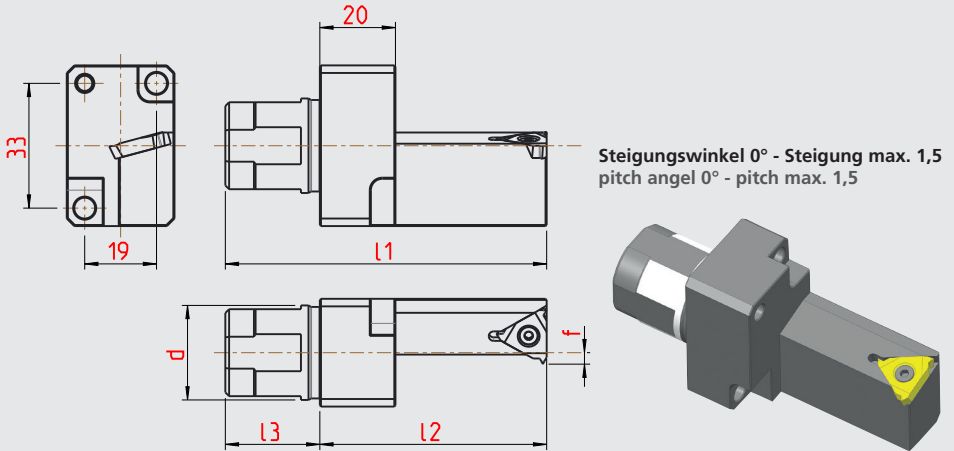

Ausführung rechtsschneidend, wie dargestellt · right cutting version shown

Bestellnummer Part number	Rückseitenhalter Back holder	d	l1	l2	l3	f	für Wendeschneidplatte for cutting insert
12-1039	RHF.R.102.16ER.C2	25	85	60	25	3	16ER

Abmessungen in mm
Dimensions in mm

Ersatzteile / Spare parts

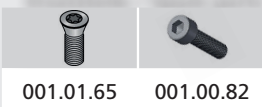

001.01.65

001.00.82

Rückseitenhalter, fest
Back holder, fixed

Lochbild C2
 hole pattern C2

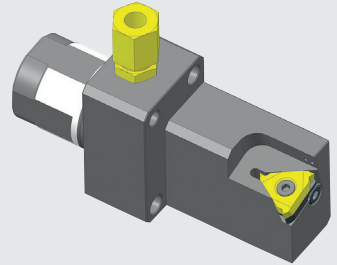
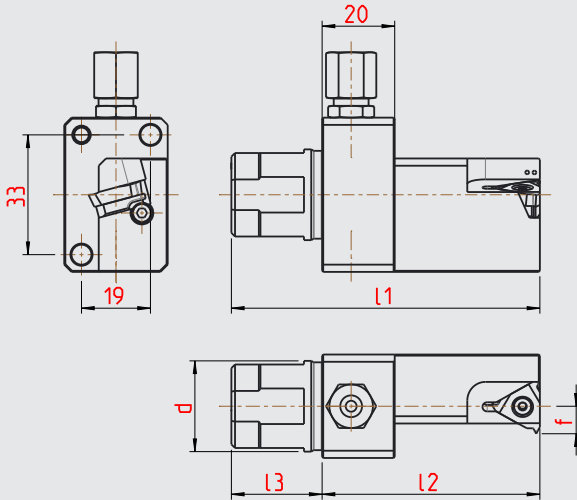

Ausführung rechtsschneidend, wie dargestellt · right cutting version shown

Bestellnummer Part number	Rückseitenhalter Back holder	d	l1	l2	l3	f	für Wendschneidplatte for cutting insert
12-1046	RHF.R.102.16ER.C2.IK	25	85	60	25	7,5	16ER
12-1176	RHF.L.102.16ER.C2.IK	25	85	60	25	7,5	16EL

Abmessungen in mm
 Dimensions in mm

Hinweis/Note:

IK Anschluss oben und unten
 coolant connection at the top and bottom

Ersatzteile / Spare parts

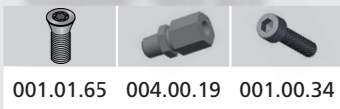

Unterlegplatte / Shim

	3° N	2° N	1° N	0°	1° P	2° P
Art. Nr. R	00200185	00200184	00200183	00200180	00200182	00200181
Art. Nr. L	00200195	00200194	00200193	00200190	00200192	00200191

Berechnung
 Steigungswinkel
 Seite 29-30!

Rückseitenhalter, fest
Back holder, fixed

Lochbild C2
hole pattern C2

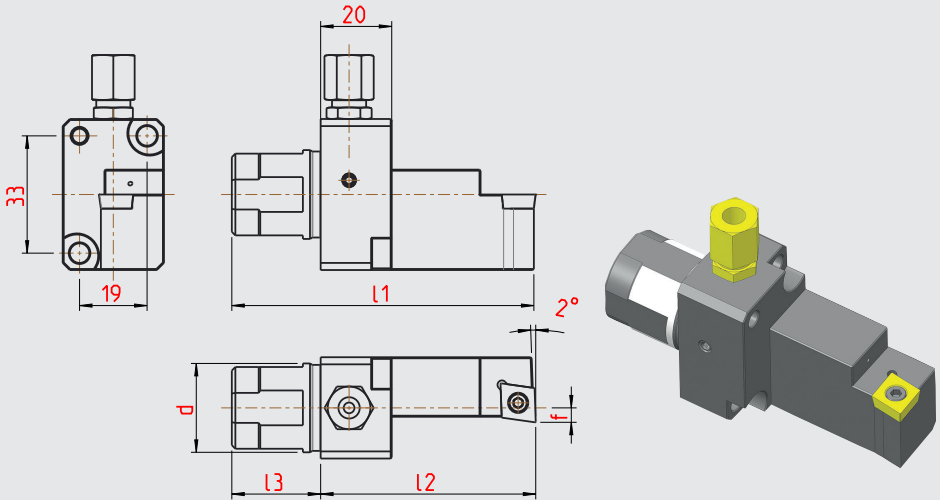

Ausführung rechtsschneidend, wie dargestellt · right cutting version shown

Bestellnummer Part number	Rückseitenhalter Back holder	d	l1	l2	l3	f	für Wendschneidplatte for cutting insert
12-1177	RHF.R.125.CC09.C2.IK	25	85	60	25	4	CC... 09...
12-1178	RHF.L.125.CC09.C2.IK	25	85	60	25	4	CC... 09...

Abmessungen in mm
Dimensions in mm

Hinweis/Note:

IK Anschluss oben und unten
coolant connection at the top and bottom

Ersatzteile / Spare parts



001.01.15 004.00.19 001.00.82

Rückseitenhalter, fest
Back holder, fixed

Lochbild C2
 hole pattern C2

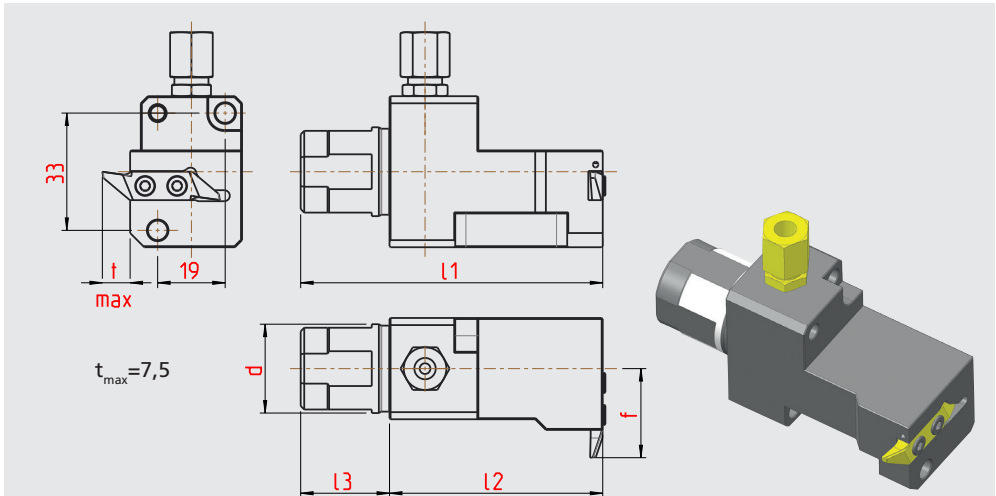

Ausführung rechtsschneidend, wie dargestellt · right cutting version shown

Bestellnummer Part number	Rückseitenhalter Back holder	d	l1	l2	l3	f	für Wendschneidplatte for cutting insert
12-1179	RHF.R.141.G0004.C2.IK	25	85	60	25	25	GRAF-G0004
12-1180	RHF.L.141.G0004.C2.IK	25	85	60	25	25	GRAF-G0004

Abmessungen in mm
 Dimensions in mm

Hinweis/Note:

IK Anschluss oben und unten
 coolant connection at the top and bottom

Ersatzteile / Spare parts

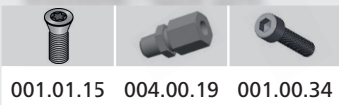

Rückseitenhalter, fest
Back holder, fixed

Lochbild C2
hole pattern C2

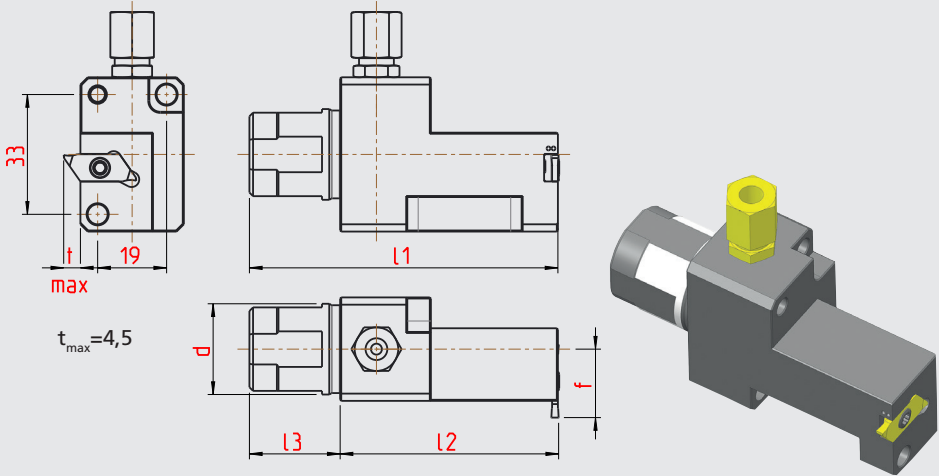

Ausführung rechtsschneidend, wie dargestellt · right cutting version shown

Bestellnummer Part number	Rückseitenhalter Back holder	d	l1	l2	l3	f	für Wendschneidplatte for cutting insert
12-1181	RHF.R.140.S274.C2.IK	25	85	60	25	19	Horn Typ S274
12-1182	RHF.L.140.S274.C2.IK	25	85	60	25	19	Horn Typ S274

Abmessungen in mm
Dimensions in mm

Hinweis/Note:

IK Anschluss oben und unten
coolant connection at the top and bottom

Ersatzteile / Spare parts



001.01.39 004.00.19 001.00.34

Rückseitenhalter, fest
Back holder, fixed



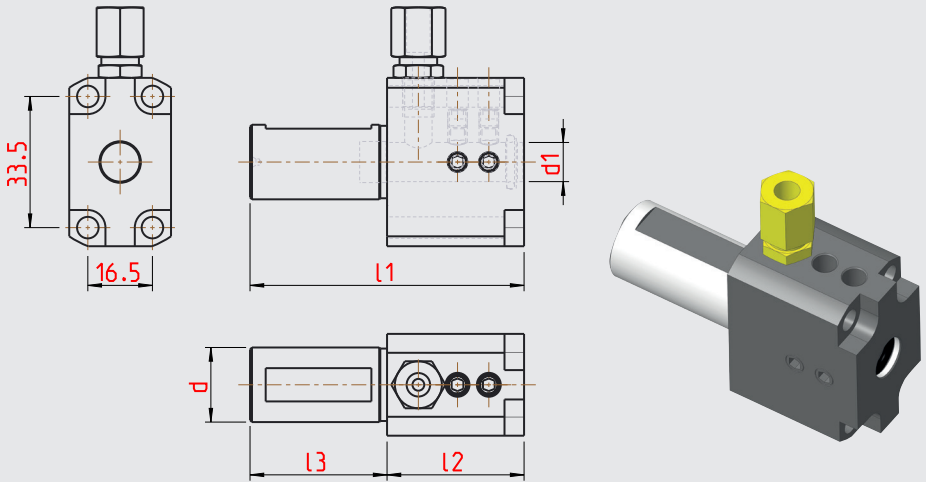

Lochbild C3
 hole pattern C3



Bestellnummer Part number	Rückseitenhalter Back holder	d	d1	l1	l2	l3	für Reduzierhülsen for reduction sleeves
11-1190	BHE73.3435.08.C3	¾"	08	70	35	35	
11-1188	BHE73.3435.10.C3	¾"	10	70	35	35	RH10
11-1189	BHE73.3435.12.C3	¾"	12	70	35	35	RH12

Abmessungen in mm
 Dimensions in mm

Ersatzteile / Spare parts

				Für for
002.00.07	004.00.19	002.00.111	001.00.80	11-1190
002.00.07	004.00.19	002.00.101	001.00.80	11-1188
002.00.07	004.00.19	002.00.109	001.00.80	11-1189

Rückseitenhalter, fest
Back holder, fixed

Lochbild C4
hole pattern C4

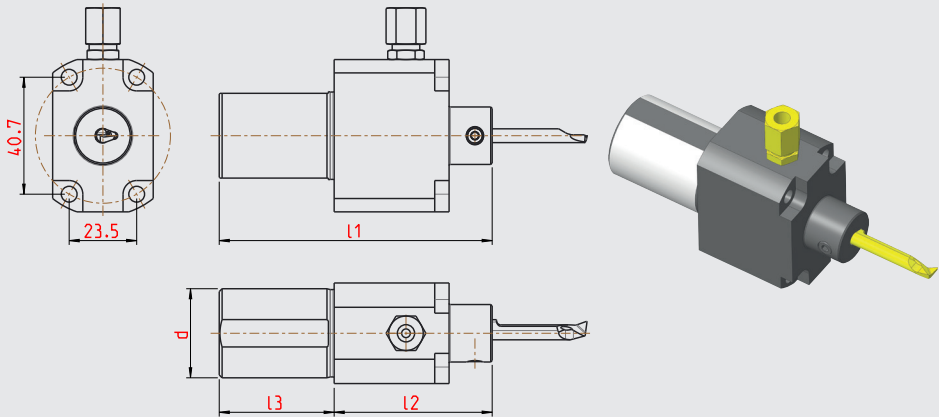

Bestellnummer Part number	Rückseitenhalter Back holder	d	l1	l2	l3	für Schneideinsatz for insert
12-1222	RHF.N.170.H105.C4.IK	31	95	55	40	Horn Typ 105

Abmessungen in mm
Dimensions in mm

Hinweis/Note:

IK Anschluss oben und unten
coolant connection at the top and bottom

Ersatzteile / Spare parts



001.01.36 004.00.19 001.00.97

Rückseitenhalter, fest
Back holder, fixed

Lochbild C4
 hole pattern C4

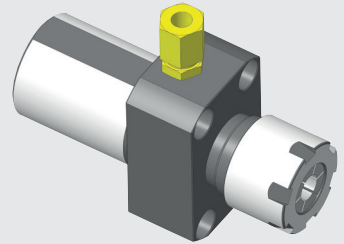
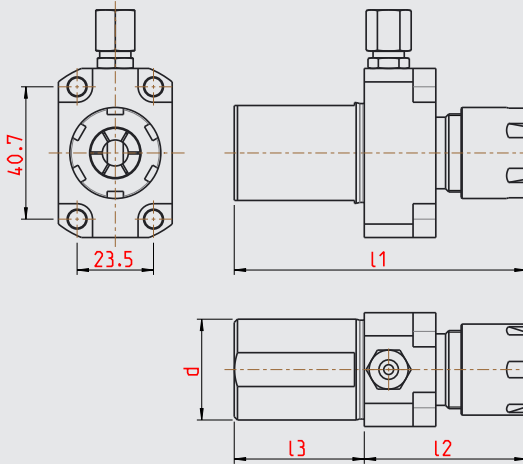

Bestellnummer Part number	Rückseitenhalter Back holder	d	l1	l2	l3	für Spannzange for collet
11-1194	GZ65.3140.16.C4	31	98	58	40	ER16
11-1184	GZ65.3140.20.C4	31	90	50	40	ER20

Abmessungen in mm
 Dimensions in mm

Hinweis/Note:

IK Anschluss oben und unten
 coolant connection at the top and bottom

Ersatzteile / Spare parts

		
004.00.19	62.000.16	001.00.14
004.00.19	62.000.20	001.00.82

Abdichtbare Spannmutter muß separat bestellt werden.
 Sealed chucking nut must be orderd separately.

Rückseitenhalter, fest
Back holder, fixed



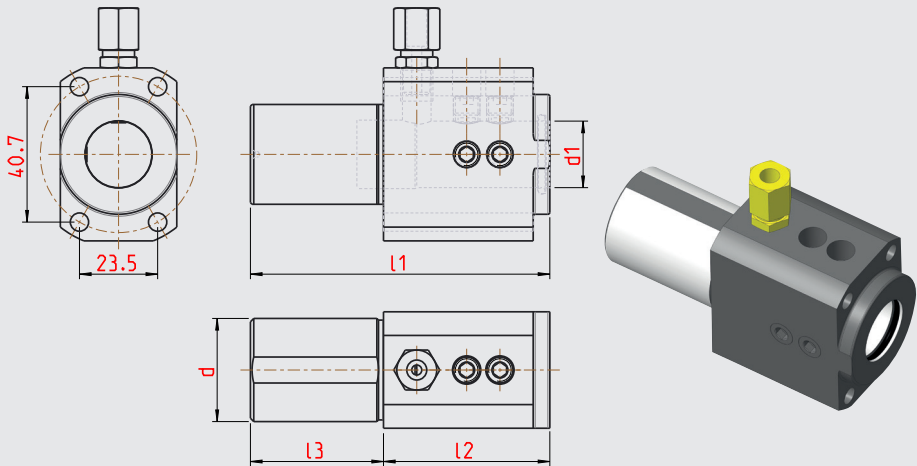

Lochbild C4
hole pattern C4



Bestellnummer Part number	Rückseitenhalter Back holder	d	d1	l1	l2	l3	für Reduzierhülsen for reduction sleeves
11-1196	BHE73.3140.16.C4	31	16	90	50	40	RH16
11-1197	BHE73.3140.20.C4	31	20	90	50	40	RH20
11-1198	BHE73.3140.25.C4	31	25	80	40	40	RH25

Abmessungen in mm
Dimensions in mm

Ersatzteile / Spare parts

				Für for
002.00.31	004.00.19	002.00.103	001.00.30	11-1196
002.00.80	004.00.19	002.00.104	001.00.30	11-1197
002.00.31	004.00.19	002.00.116	001.00.97	11-1198

Rückseitenhalter, fest
Back holder, fixed

Lochbild C4
 hole pattern C4

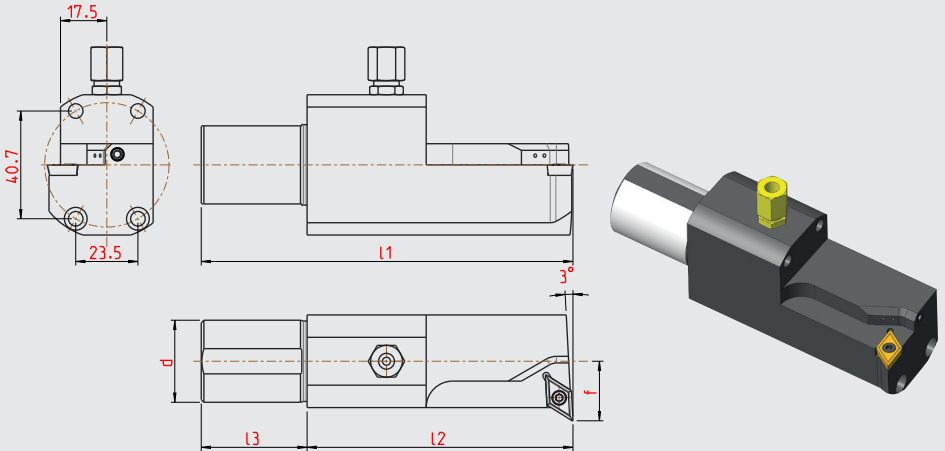

Ausführung rechtsschneidend, wie dargestellt · right cutting version shown

Bestellnummer Part number	Rückseitenhalter Back holder	d	l1	l2	l3	f	für Wendeschneidplatte for cutting insert
12-1223	RHF.R.162.DC11.C4.IK	31	140,5	100,5	40	22,5	DC... 11...
12-1224	RHF.L.162.DC11.C4.IK	31	140,5	100,5	40	22,5	DC... 11...

Abmessungen in mm
 Dimensions in mm

Hinweis/Note:

IK Anschluss oben und unten
 coolant connection at the top and bottom

Ersatzteile / Spare parts

		
001.01.15	004.00.19	001.00.30
		001.00.20

Rückseitenhalter, fest
Back holder, fixed

Lochbild C4
hole pattern C4

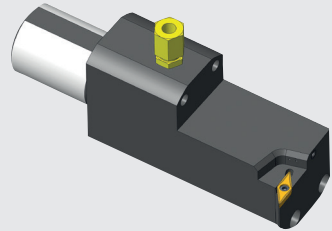
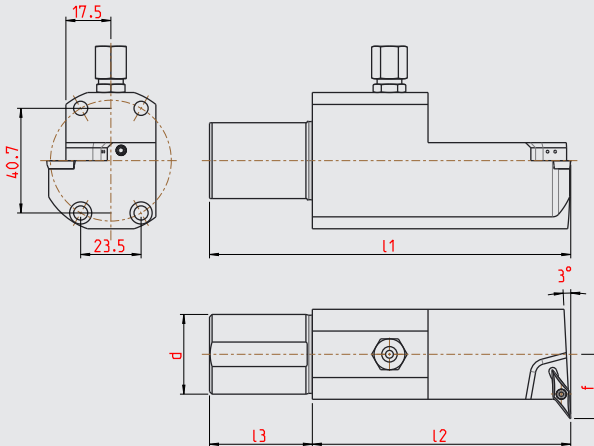

Ausführung rechtsschneidend, wie dargestellt · right cutting version shown



Bestellnummer Part number	Rückseitenhalter Back holder	d	l1	l2	l3	f	für Wendschneidplatte for cutting insert
12-1225	RHFR.168.VC11.C4.IK	31	140,5	100,5	40	22,5	VC... 11...
12-1226	RHFL.168.VC11.C4.IK	31	140,5	100,5	40	22,5	VC... 11...

Abmessungen in mm
Dimensions in mm

Hinweis/Note:

IK Anschluss oben und unten
coolant connection at the top and bottom

Ersatzteile / Spare parts

		
001.01.08	004.00.19	001.00.30
		001.00.20

Rückseitenhalter, fest
Back holder, fixed

Lochbild C4
 hole pattern C4

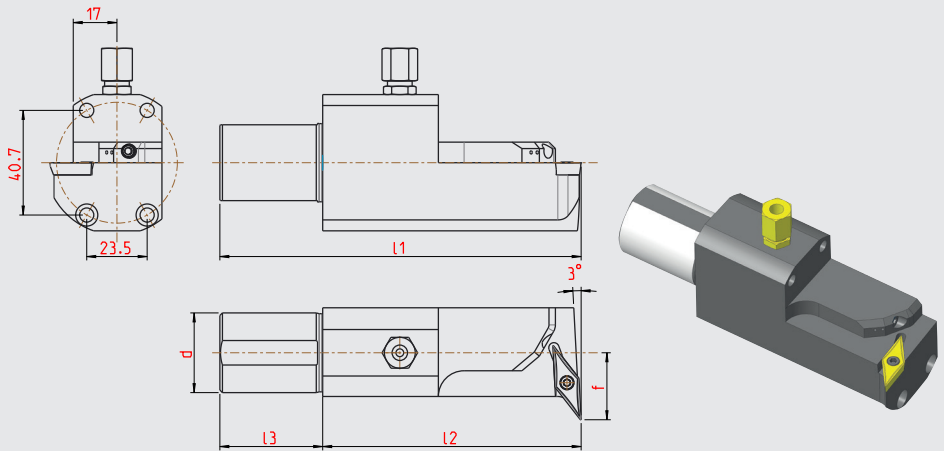

Ausführung rechtsschneidend, wie dargestellt · right cutting version shown



Bestellnummer Part number	Rückseitenhalter Back holder	d	l1	l2	l3	f	für Wendeschneidplatte for cutting insert
12-1227	RHF.R.164.VC16.C4.IK	31	140,5	100,5	40	26	VC... 16...
12-1228	RHF.L.164.VC16.C4.IK	31	140,5	100,5	40	26	VC... 16...

Abmessungen in mm
 Dimensions in mm

Hinweis/Note:

IK Anschluss oben und unten
 coolant connection at the top and bottom

Ersatzteile / Spare parts

		
001.01.08	004.00.19	001.00.30
001.01.15		001.00.20

Rückseitenhalter, fest
Back holder, fixed

Lochbild C4
hole pattern C4

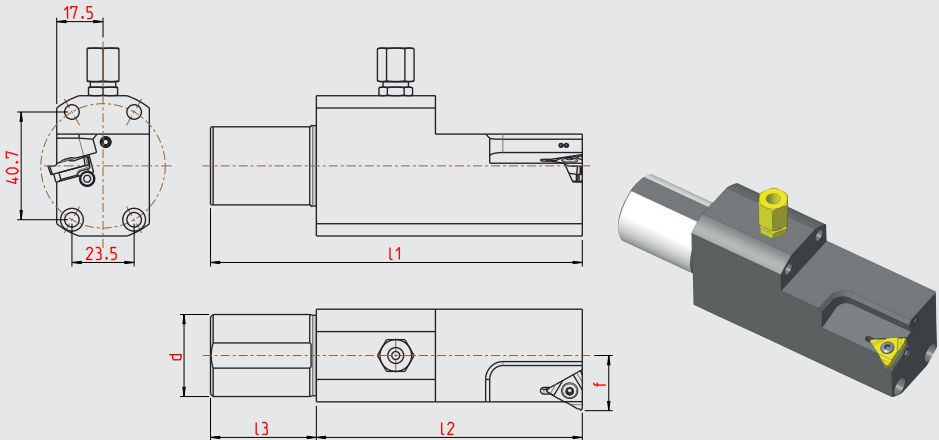

Ausführung rechtsschneidend, wie dargestellt · right cutting version shown

Bestellnummer Part number	Rückseitenhalter Back holder	d	l1	l2	l3	f	für Wendeschneidplatte for cutting insert
12-1229	RHF.R.167.16ER.C4.IK	31	140,5	100,5	40	20,5	16ER
12-1230	RHFL.167.16EL.C4.IK	31	140,5	100,5	40	20,5	16EL

Abmessungen in mm
Dimensions in mm

Hinweis/Note:

IK Anschluss oben und unten
coolant connection at the top and bottom

Ersatzteile / Spare parts



Unterlegplatte / Shim

	3° N	2° N	1° N	0°	1° P	2° P
Art. Nr. R	00200185	00200184	00200183	00200180	00200182	00200181
Art. Nr. L	00200195	00200194	00200193	00200190	00200192	00200191

Berechnung
Steigungswinkel
Seite 14-15!

Rückseitenhalter, fest
Back holder, fixed

Lochbild C4
 hole pattern C4

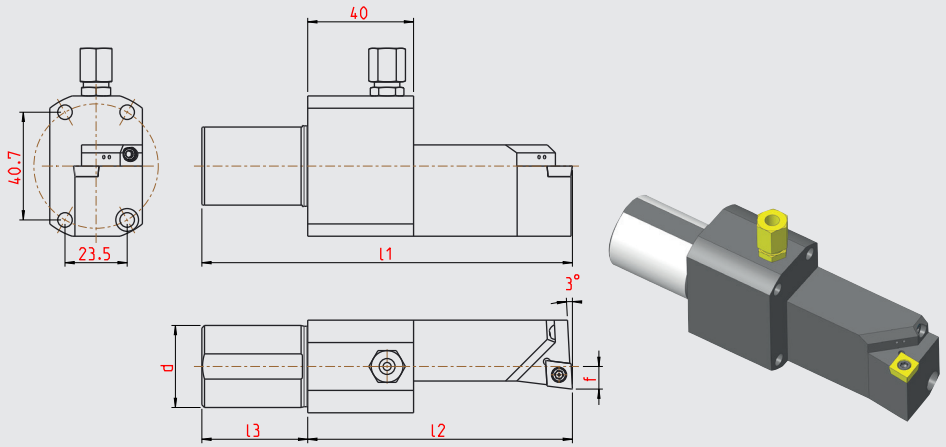

Ausführung rechtsschneidend, wie dargestellt · right cutting version shown

Bestellnummer Part number	Rückseitenhalter Back holder	d	l1	l2	l3	f	für Wendeschneidplatte for cutting insert
12-1231	RHF.R.165.CC09.C4.IK	31	140	100	40	8,5	CC... 09...
12-1232	RHF.L.165.CC09.C4.IK	31	140	100	40	8,5	CC... 09...

Abmessungen in mm
 Dimensions in mm

Hinweis/Note:

IK Anschluss oben und unten
 coolant connection at the top and bottom

Ersatzteile / Spare parts

		
001.01.15	004.00.19	001.00.82
		001.00.20

Rückseitenhalter, fest
Back holder, fixed

Lochbild C4
hole pattern C4

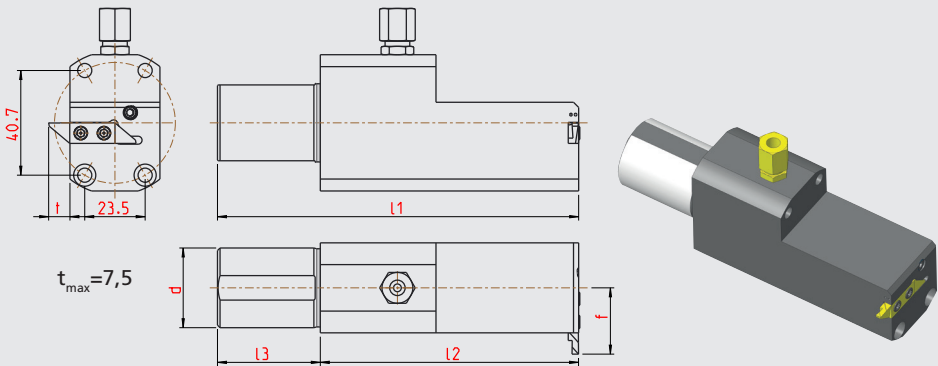

Ausführung rechtsschneidend, wie dargestellt · right cutting version shown

Bestellnummer Part number	Rückseitenhalter Back holder	d	l1	l2	l3	f	für Wendschneidplatte for cutting insert
12-1233	RHFR.166.G0004.C4.IK	31	140,5	100,5	40	25,5	GRAF-G0004
12-1234	RHFL.166.G0004.C4.IK	31	140,5	100,5	40	25,5	GRAF-G0004

Abmessungen in mm
Dimensions in mm

Hinweis/Note:

IK Anschluss oben und unten
coolant connection at the top and bottom

Ersatzteile / Spare parts

		
001.01.15	004.00.19	001.00.30
		001.00.20

Rückseitenhalter, fest
Back holder, fixed

Lochbild C4
 hole pattern C4

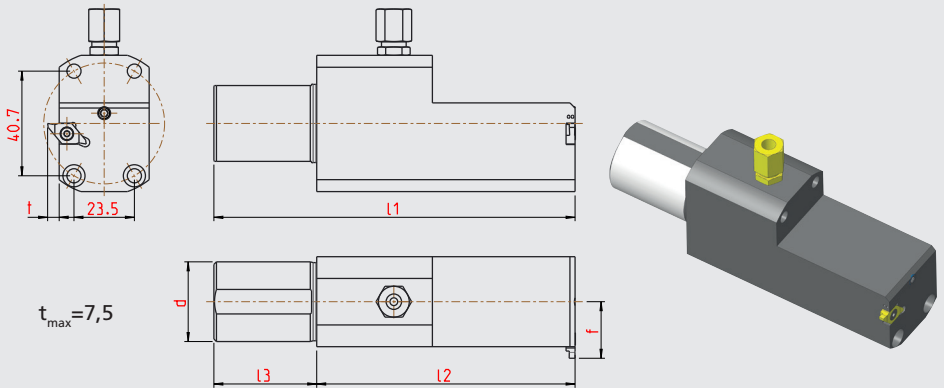

Ausführung rechtsschneidend, wie dargestellt · right cutting version shown



Bestellnummer Part number	Rückseitenhalter Back holder	d	l1	l2	l3	f	für Wendeschneidplatte for cutting insert
12-1235	RHF.R.171.CS08.C4.IK	31	140,5	100,5	40	22	CS08, SCD08...
12-1236	RHF.L.171.CS08.C4.IK	31	140,5	100,5	40	22	CS08, SCD08...

Abmessungen in mm
 Dimensions in mm

Hinweis/Note:

IK Anschluss oben und unten
 coolant connection at the top and bottom

Ersatzteile / Spare parts

		
001.01.04	004.00.19	001.00.30
		001.00.20

Rückseitenhalter, fest
Back holder, fixed

Lochbild C4
hole pattern C4

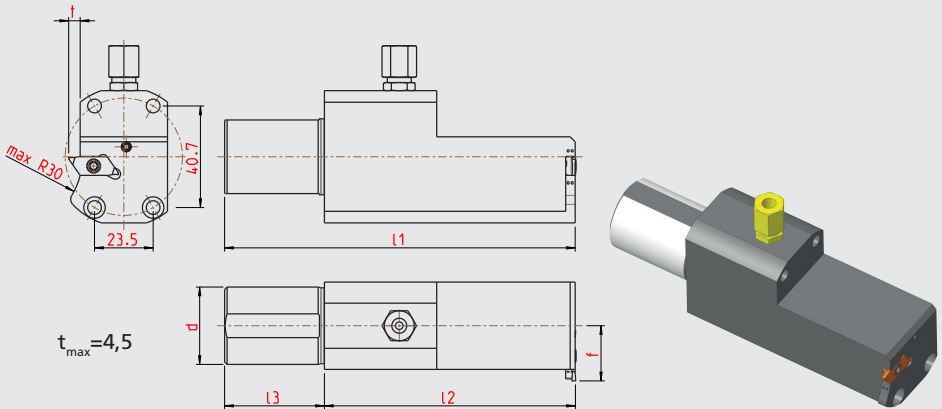

Ausführung rechtsschneidend, wie dargestellt · right cutting version shown



Bestellnummer Part number	Rückseitenhalter Back holder	d	l1	l2	l3	f	für Wendschneidplatte for cutting insert
12-1237	RHF.R.169.S274.C4.IK	31	140,5	100,5	40	22	Horn Typ S274
12-1238	RHF.L.169.S274.C4.IK	31	140,5	100,5	40	22	Horn Typ S274

Abmessungen in mm
Dimensions in mm

Hinweis/Note:

IK Anschluss oben und unten
coolant connection at the top and bottom

Ersatzteile / Spare parts

		
001.01.39	004.00.19	001.00.30
		001.00.20

Berechnung des Steigungswinkel β

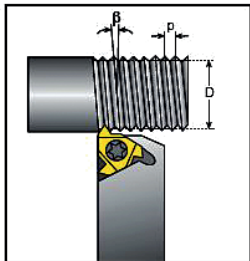

Der Steigungswinkel wird mit folgender Formel berechnet:

$$\beta = \arctan \frac{P \times N}{\pi \times D}$$

β - Steigungswinkel [°]
 P - Teilung [mm]
 N - Anzahl der Gänge
 D - Flankendurchmesser [mm]
 Steigung L = P x N

Der Steigungswinkel kann ebenfalls aus dem untenstehenden Diagramm abgelesen werden.

Steigungswinkeldiagramm

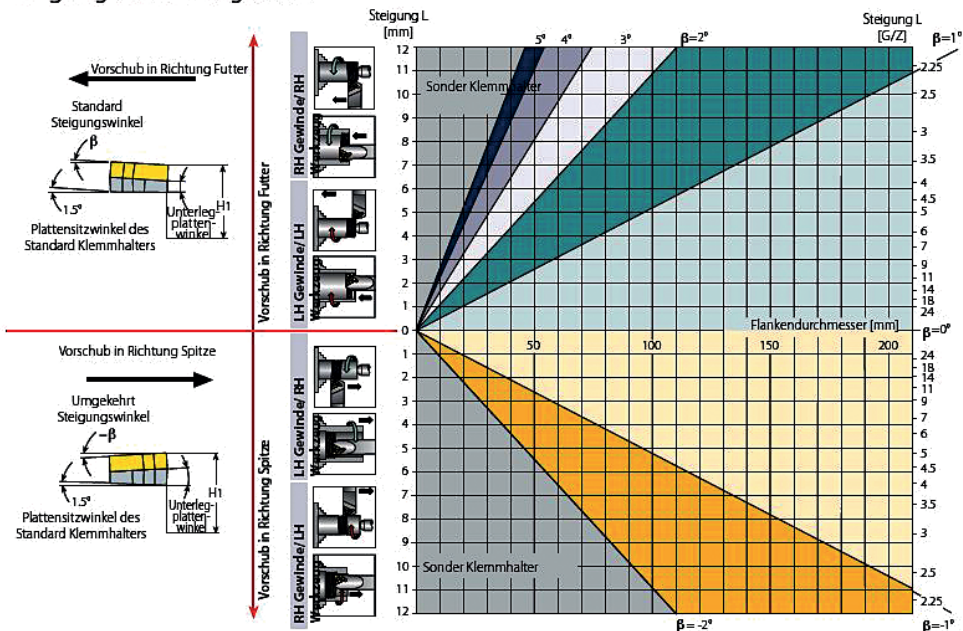

Resultierender Steigungswinkel		4,5°	3,5°	2,5°	1,5°	0,5°	0°	-0,5°	-1,5°
Plattengröße 16 mm	Plattenwinkel	3°P	2°P	1°P	0°	1°N	1,5°N	2°N	3°N
	Artikelnummer R	002.00.186	002.00.181	002.00.182	002.00.180	002.00.183	002.00.187	002.00.184	002.00.185
	Artikelnummer L	002.00.196	002.00.191	002.00.192	002.00.190	002.00.193	002.00.197	002.00.194	002.00.195

Calculating the Helix Angle β

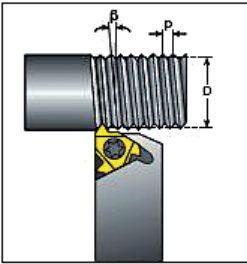

The helix angle is calculated by the following formula:

$$\beta = \arctan \frac{P \times N}{\pi \times D}$$

β - Helix angle [°]
P - Pitch [mm]
N - No. of starts
D - Pitch diameter [mm]
Lead = P x N

The helix angle can also be found from the diagram below.

Helix Angle Diagram

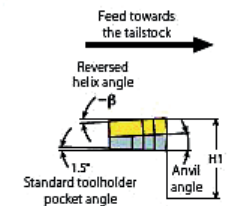
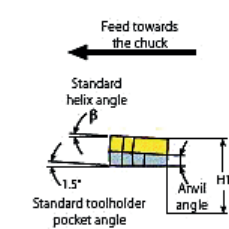

The dimension H1 (cutting edge height) remains constant with every insert/ anvil combination.

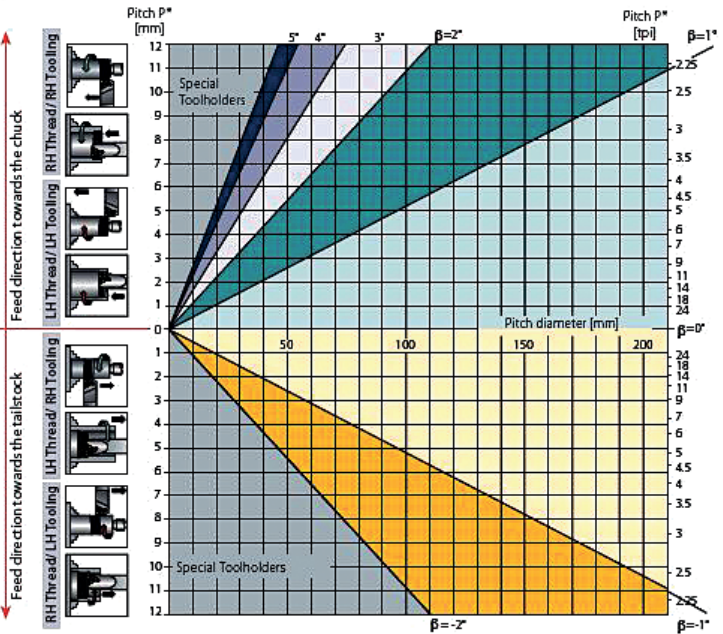

*For Multi-start threads, use the lead value instead of the pitch

resultant pitch angle		4,5°	3,5°	2,5°	1,5°	0,5°	0°	-0,5°	-1,5°
Insert size 16 mm	shim angle	3°P	2°P	1°P	0°	1°N	1,5°N	2°N	3°N
	article number R	002.00.186	002.00.181	002.00.182	002.00.180	002.00.183	002.00.187	002.00.184	002.00.185
	article number L	002.00.196	002.00.191	002.00.192	002.00.190	002.00.193	002.00.197	002.00.194	002.00.195

Das GRAF-Werkzeugprogramm mit Innenkühlung.
Fordern Sie die neuesten Unterlagen an!

The GRAF-Tool program with interior cooling.
Ask for the latest documents!

